

Air Conditioners

Indoor unit

PKA-M·KA(L) Series

English is original.	OPERATION MANUAL	FOR USER	English
Übersetzung des Originals.	BEDIENUNGSHANDBUCH	FÜR BENUTZER	Deutsch
Traduction du texte d'origine.	MANUEL D'UTILISATION	POUR L'UTILISATEUR	Français
Vertaling van het origineel.	BEDIENINGSHANDLEIDING	VOOR DE GEBRUIKER	Nederlands
Traducción del original.	MANUAL DE INSTRUCCIONES	PARA EL USUARIO	Español
Traduzione dell'originale.	ISTRUZIONI DI FUNZIONAMENTO	PER L'UTENTE	Italiano
Μετάφραση του αρχικού.	ΕΓΧΕΙΡΙΔΙΟ ΟΔΗΓΙΩΝ ΧΡΗΣΕΩΣ	ΓΙΑ ΤΟΝ ΧΡΗΣΤΗ	Ελληνικό
Tradução do original.	MANUAL DE OPERAÇÃO	PARA O UTILIZADOR	Português
Oversættelse af den originale tekst.	DRIFTSMANUAL	TIL BRUGER	Dansk
Översättning från originalet.	DRIFTSMANUAL	FÖR ANVÄNDAREN	Svenska
Aslı İngilizcedir.	İŞLETME EL KİTABI	KULLANICI İÇİN	Türkçe
Перевод оригинала.	РУКОВОДСТВО ПО ЭКСПЛУАТАЦИИ	ДЛЯ ПОЛЬЗОВАТЕЛЯ	Русский
Переклад оригіналу.	ПОСІБНИК З ЕКСПЛУАТАЦІЇ	ДЛЯ КОРИСТУВАЧА	Українська
Оригиналът е текстът на английски език.	РЪКОВОДСТВО ЗА ЕКСПЛОАТАЦИЯ	ЗА ПОТРЕБИТЕЛЯ	Български
Językiem oryginału jest język angielski.	INSTRUKCJA OBSŁUGI	INFORMACJA DLA UŻYTKOWNIKA	Polski
Originalspråket er engelsk.	BRUKSANVISNING	FOR BRUKER	Norsk
Englanti on alkuperäinen.	KÄYTTÖOPAS	KÄYTTÄJÄLLE	Suomi
Originál je v angličtině.	PROVOZNÍ PŘÍRUČKA	PRO UŽIVATELE	Čeština
Preklad anglického originálu.	NÁVOD NA OBSLUHU	PRE POUŽIVATEĽA	Slovenčina
Az angol változat az eredeti.	HASZNÁLATI KÉZIKÖNYV	A FELHASZNÁLÓNAK	Magyar
Izvirnik je v angleščini.	NAVODILA ZA UPORABO	ZA UPORABNIKA	Slovenščina
Textul original este în limba engleză.	MANUAL DE UTILIZARE	PENTRU UTILIZATOR	Română
Originaaljuhend on ingliskeelne.	KASUTUSJUHEND	KASUTAJALE	Eesti
Orīģināls ir angļu valodā.	LIETOŠANAS ROKASGRĀMATA	LIETOTĀJIEM	Latviski
Originalas yra anglų k.	NAUDOJIMO VADOVAS	SKIRTA NAUDOTOJUI	Lietuviškai
Jezik originala je engleski.	PRIRUČNIK ZA RUKOVANJE	ZA KORISNIKA	Hrvatski
Prevod originala.	UPUTSTVO ZA RUKOVANJE	ZA KORISNIKA	Srpski

1. Safety Precautions	1	5. Emergency Operation for Wireless Remote-controller	9
2. Parts Names	2	6. Care and Cleaning	10
3. Operation	6	7. Troubleshooting	12
4. Timer	9	8. Specifications	13

Note



Fig. 1

This symbol mark is for EU countries only.

This symbol mark is according to the directive 2012/19/EU Article 14 Information for users and Annex IX, and/or to the directive 2006/66/EC Article 20 Information for end-users and Annex II.

Your MITSUBISHI ELECTRIC product is designed and manufactured with high quality materials and components which can be recycled and/or reused. This symbol means that electrical and electronic equipment, batteries and accumulators, at their end-of-life, should be disposed of separately from your household waste. If a chemical symbol is printed beneath the symbol (Fig. 1), this chemical symbol means that the battery or accumulator contains a heavy metal at a certain concentration.

This will be indicated as follows: Hg: mercury (0.0005%), Cd: cadmium (0.002%), Pb: lead (0.004%)

In the European Union there are separate collection systems for used electrical and electronic products, batteries and accumulators. Please, dispose of this equipment, batteries and accumulators correctly at your local community waste collection/recycling centre. Please, help us to conserve the environment we live in!

Note:

The phrase "Wired remote controller" in this operation manual refers only to the PAR-41MAA.

If you need any information for the other remote controller, please refer to the instruction book included in this box.

1. Safety Precautions

- ▶ Before installing the unit, make sure you read all the "Safety Precautions".
- ▶ The "Safety Precautions" provide very important points regarding safety. Make sure you follow them.
- ▶ Please report to or take consent by the supply authority before connection to the system.

MEANINGS OF SYMBOLS DISPLAYED ON THE UNIT

	WARNING (Risk of fire)	This mark is for R32 refrigerant only. Refrigerant type is written on nameplate of outdoor unit. In case that refrigerant type is R32 this unit uses a flammable refrigerant. If refrigerant leaks and comes in contact with fire or heating part, it will create harmful gas and there is risk of fire.
		Read the OPERATION MANUAL carefully before operation.
		Service personnel are required to carefully read the OPERATION MANUAL and INSTALLATION MANUAL before operation.
		Further information is available in the OPERATION MANUAL, INSTALLATION MANUAL, and the like.

Symbols used in the text

⚠ Warning:

Describes precautions that should be observed to prevent danger of injury or death to the user.

⚠ Caution:

Describes precautions that should be observed to prevent damage to the unit.

⚠ Warning:

- There appliances are not accessible to the general public.
- The unit must not be installed by the user. Ask the dealer or an authorized company to install the unit. If the unit is installed improperly, water leakage, electric shock or fire may result.
- Do not alter the unit. It may cause fire, electric shock, injury or water leakage.
- The unit must be securely installed on a structure that can sustain its weight.
- Do not stand on, or place any items on the unit.
- Do not splash water over the unit and do not touch the unit with wet hands. An electric shock may result.
- Do not spray combustible gas close to the unit. Fire may result.
- Do not place a gas heater or any other open-flame appliance where it will be exposed to the air discharged from the unit. Incomplete combustion may result.
- Do not remove the front panel or the fan guard from the outdoor unit when it is running.
- When you notice exceptionally abnormal noise or vibration, stop operation, turn off the power switch, and contact your dealer.
- Never insert fingers, sticks etc. into the air inlets or outlets.
- If you detect odd smells, stop using the unit, turn off the power switch and consult your dealer. Otherwise, a breakdown, electric shock or fire may result.
- This air conditioner is NOT intended for use by children or infirm persons without supervision.
- This appliance is intended to be used by expert or trained users in shops, in light industry and on farms, or for commercial use by lay persons.
- Young children must be supervised to ensure that they do not play with the air conditioner.
- If the refrigeration gas blows out or leaks, stop the operation of the air conditioner, thoroughly ventilate the room, and contact your dealer.
- This appliance can be used by children aged from 8 years and above and persons with reduced physical, sensory or mental capabilities or lack of experience and knowledge if they have been given supervision or instruction concerning use of the appliance in a safe way and understand the hazards involved. Children shall not play with the appliance. Cleaning and user maintenance shall not be made by children without supervision.

Symbols used in the illustrations

: Indicates a part which must be grounded.

- This appliance is not intended for use by persons (including children) with reduced physical, sensory or mental capabilities, or lack of experience and knowledge, unless they have been given supervision or instruction concerning use of the appliance by a person responsible for their safety.
- When installing or relocating, or servicing the air conditioner, use only the specified refrigerant written on outdoor unit to charge the refrigerant lines. Do not mix it with any other refrigerant and do not allow air to remain in the lines.
If air is mixed with the refrigerant, then it can be the cause of abnormal high pressure in the refrigerant line, and may result in an explosion and other hazards. The use of any refrigerant other than that specified for the system will cause mechanical failure or system malfunction or unit breakdown. In the worst case, this could lead to a serious impediment to securing product safety.
- Children should be supervised to ensure that they do not play with the air conditioner.
- This unit should be installed in rooms which exceed the floor space specified in outdoor unit installation manual.
Refer to outdoor unit installation manual.
- Do not use means to accelerate the defrosting process or to clean, other than those recommended by the manufacturer.
- The appliance shall be stored in a room without continuously operating ignition sources (for example: open flames, an operating gas appliance or an operating electric heater).
- Do not pierce or burn.
- Be aware that refrigerants may not contain an odour.

1. Safety Precautions

⚠ Caution:

- Do not use any sharp object to push the buttons, as this may damage the remote controller.
- Never block or cover the indoor or outdoor unit's air inlets or outlets.
- Never wipe the remote controller with benzene, thinner chemical rags, etc.
- Do not operate the unit for a long time in high humidity, e.g. leaving a door or window open. In the cooling mode, if the unit is operated in a room with high humidity (80% RH or more) for a long time, water condensed in the air conditioner may drop and wet or damage furniture, etc.
- Do not touch the upper air outlet vane or the lower air outlet damper during operation. Otherwise, condensation may form and the unit may stop operating.

- Refrigerant leakage may cause suffocation. Provide ventilation in accordance with EN378-1.
- Be sure to wrap insulation around the piping. Direct contact with the bare piping may result in burns or frostbite.
- Never put batteries in your mouth for any reason to avoid accidental ingestion.
- Battery ingestion may cause choking and/or poisoning.
- Install the unit on a rigid structure to prevent excessive operation sound or vibration.
- Noise measurement is carried out in accordance with JIS C9612, JIS B8616, ISO 5151(T1), and ISO 13523(T1).

Disposing of the unit

When you need to dispose of the unit, consult your dealer.

2. Parts Names

■ Indoor Unit

	PKA-M·KA(L) Series
Fan speed	3 speeds (with auto)
Vane	Auto swing
Louver	Manual
Filter	Normal
Filter cleaning indication	100 hr
Wireless remote controller model No. setting	002

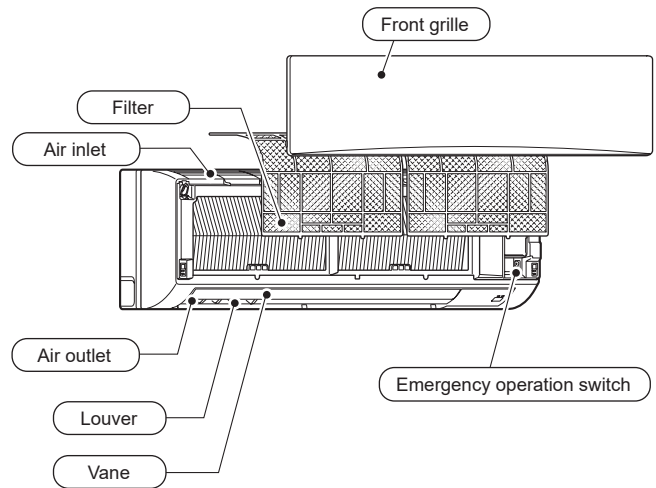

en

2. Parts Names

■ Wired Remote Controller

Controller interface

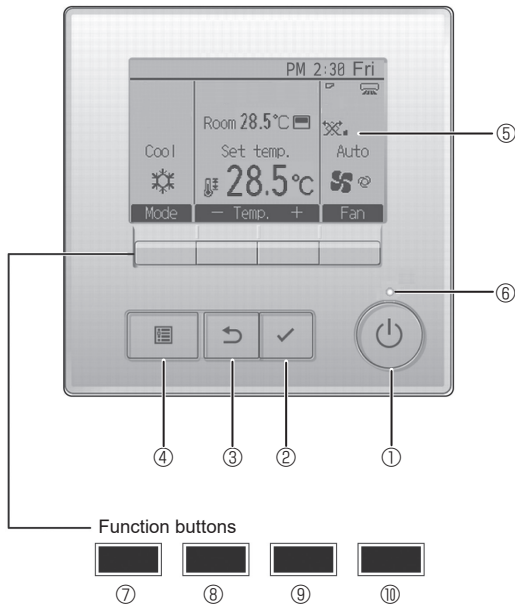

The functions of the function buttons change depending on the screen.

Refer to the button function guide that appears at the bottom of the LCD for the functions they serve on a given screen.

When the system is centrally controlled, the button function guide that corresponds to the locked button will not appear.

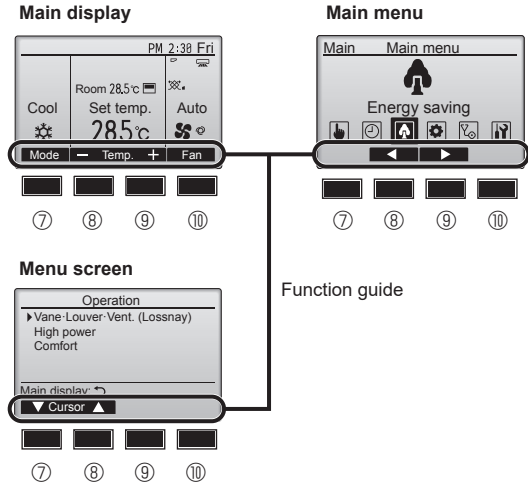

① [ON/OFF] button

Press to turn ON/OFF the indoor unit.

② [SELECT] button

Press to save the setting.

③ [RETURN] button

Press to return to the previous screen.

④ [MENU] button

Press to bring up the Main menu.

⑤ Backlit LCD

Operation settings will appear.

When the backlight is off, pressing any button turns the backlight on and it will stay lit for a certain period of time depending on the screen.

When the backlight is off, pressing any button turns the backlight on and does not perform its function. (except for the [ON/OFF] button)

⑥ ON/OFF lamp

This lamp lights up in green while the unit is in operation. It blinks while the remote controller is starting up or when there is an error.

⑦ Function button [F1]

Main display: Press to change the operation mode.

Menu screen: The button function varies with the screen.

⑧ Function button [F2]

Main display: Press to decrease temperature.

Main menu: Press to move the cursor left.

Menu screen: The button function varies with the screen.

⑨ Function button [F3]

Main display: Press to increase temperature.

Main menu: Press to move the cursor right.

Menu screen: The button function varies with the screen.

⑩ Function button [F4]

Main display: Press to change the fan speed.

Menu screen: The button function varies with the screen.

2. Parts Names

Display

The main display can be displayed in two different modes: "Full" and "Basic". The factory setting is "Full". To switch to the "Basic" mode, change the setting on the Main display setting. (Refer to operation manual included with remote controller.)

<Full mode>

* All icons are displayed for explanation.

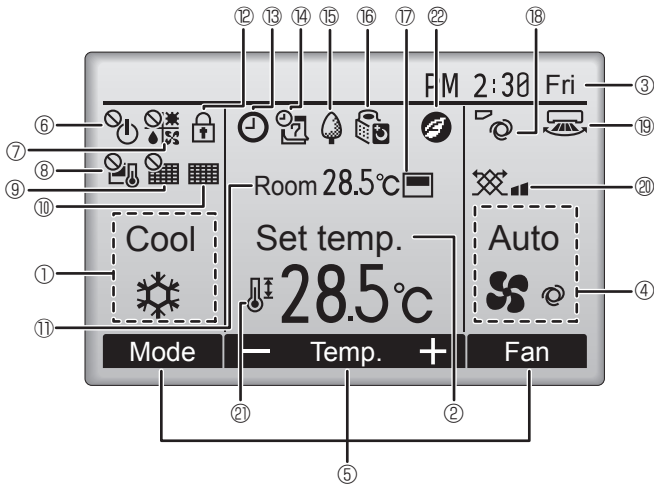

<Basic mode>

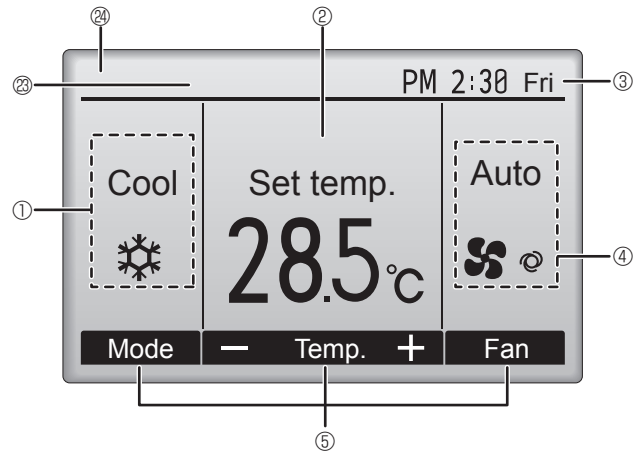

① Operation mode

② Preset temperature

③ Clock

④ Fan speed

⑤ Button function guide

Functions of the corresponding buttons appear here.



Appears when the ON/OFF operation is centrally controlled.



Appears when the operation mode is centrally controlled.



Appears when the preset temperature is centrally controlled.



Appears when the filter reset function is centrally controlled.



Indicates when filter needs maintenance.

⑪ Room temperature



Appears when the buttons are locked.



Appears when the On/Off timer, Night setback, or Auto-off timer function is enabled.

appears when the timer is disabled by the centralized control system.



Appears when the Weekly timer is enabled.



Appears while the units are operated in the energy-save mode. (Will not appear on some models of indoor units)



Appears while the outdoor units are operated in the silent mode.



Appears when the built-in thermistor on the remote controller is activated to monitor the room temperature (⑪).

appears when the thermistor on the indoor unit is activated to monitor the room temperature.



Indicates the vane setting.



Indicates the louver setting.



Indicates the ventilation setting.



Appears when the preset temperature range is restricted.



Appears when an energy-saving operation is performed using a "3D i-see Sensor" function.

⑳ Centrally controlled

Appears for a certain period of time when a centrally-controlled item is operated.

㉑ Preliminary error display

An error code appears during the preliminary error.

Most settings (except ON/OFF, mode, fan speed, temperature) can be made from the Main menu.

en

2. Parts Names

■ Outdoor unit

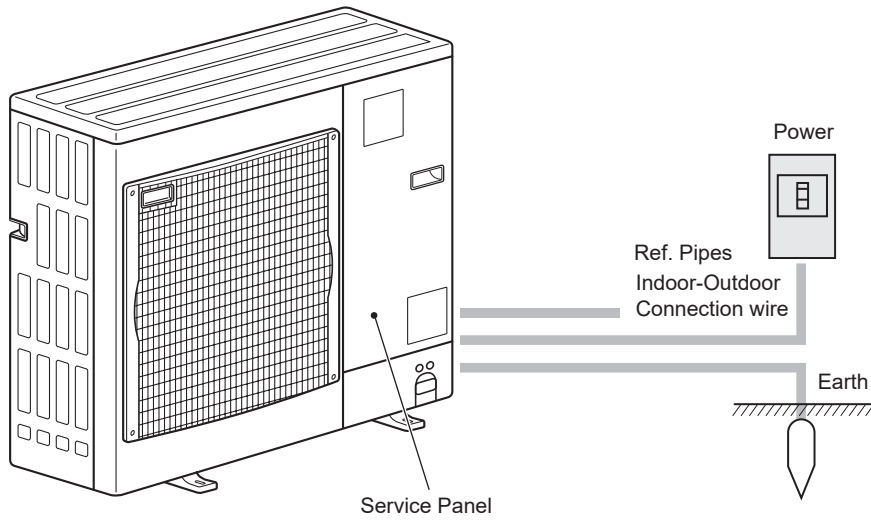

en

3. Operation

■ About the operation method, refer to the operation manual that comes with each remote controller.

3.1. Turning ON/OFF

[ON]



Press the [ON/OFF] button.
The ON/OFF lamp will light up in green, and the operation will start.

When "LED lighting" is set to "No," the ON/OFF lamp will not light up.

* Refer to the installation manual of wired remote controller.

[OFF]



Press the [ON/OFF] button again.
The ON/OFF lamp will come off, and the operation will stop.

Note:
Even if you press the ON/OFF button immediately after shutting down the operation is progress, the air conditioner will not start for about 3 minutes. This is to prevent the internal components from being damaged.

■ Operation status memory

	Remote controller setting
Operation mode	Operation mode before the power was turned off
Preset temperature	Preset temperature before the power was turned off
Fan speed	Fan speed before the power was turned off

■ Settable preset temperature range

Operation mode	Preset temperature range	
	Default	14 °C Cooling *1 *2
Cool/Dry	19 – 30 °C	14 – 30 °C
Heat	17 – 28 °C	17 – 28 °C
Auto	19 – 28 °C	17 – 28 °C
Fan/Ventilation	Not settable	Not settable

*1 It is available when the indoor unit is connected to any of the particular outdoor units.

*2 Function setting needs to be changed. Refer to the installation manual for the setting method.

3.2. Mode Selection

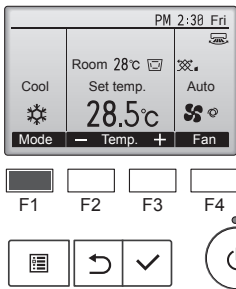

Each pressing of the [F1] button cycles through the following operation modes. Select the desired operation mode.

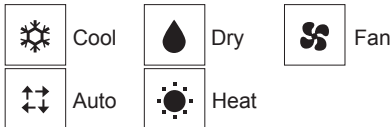

• Operation modes that are not available to the connected outdoor unit models will not appear on the display.

What the blinking mode icon means

The mode icon will blink when other indoor units in the same refrigerant system (connected to the same outdoor unit) are already operated in a different mode. In this case, the rest of the unit in the same group can only be operated in the same mode.

Automatic operation

<Single set point>

- According to a set temperature, cooling operation starts if the room temperature is too hot and heating operation starts if the room temperature is too cold.
- During automatic operation, if the room temperature changes and remains 2.0 °C or more above the set temperature for 15 minutes, the air conditioner switches to cool mode. In the same way, if the room temperature remains 2.0 °C or more below the set temperature for 15 minutes, the air conditioner switches to heat mode.

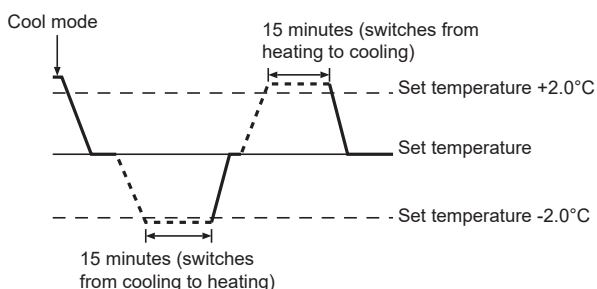

<Dual set point>

Note:

- This function cannot be set depending on the outdoor unit to be connected.

When the operation mode is set to the Auto (dual set point) mode, two preset temperatures (one each for cooling and heating) can be set. Depending on the room temperature, indoor unit will automatically operate in either the Cool or Heat mode and keep the room temperature within the preset range.

For details on how to operate, refer to manual of remote controller.

3.3. Temperature setting

<Cool, Dry, Heat, and Auto>

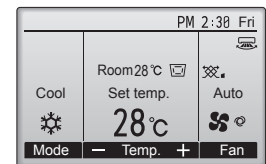
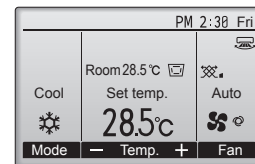

Example display
(Centigrade in 1-degree increments)



Press the [F2] button to decrease the preset temperature, and press the [F3] button to increase.

- Refer to the table on 3-1 for the settable temperature range for different operation modes.
- Preset temperature range cannot be set for Fan/Ventilation operation.
- Preset temperature will be displayed either in Centigrade in 0.5- or 1-degree increments, or in Fahrenheit, depending on the indoor unit model and the display mode setting on the remote controller.
- Refer to "Function settings" in the installation manual for the 14°C cooling setting.

3. Operation

3.4. Fan speed setting

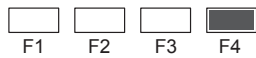
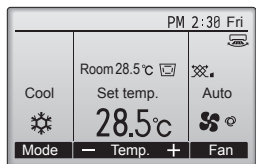

Press the [F4] button to go through the fan speeds in the following order.

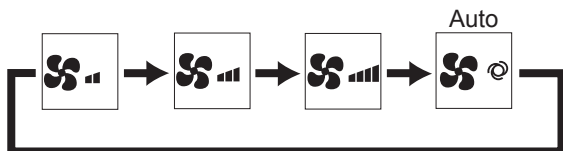

The available fan speeds depend on the models of connected indoor units.

Notes:

- The number of available fan speeds depends on the type of unit connected.
- In the following cases, the actual fan speed generated by the unit will differ from the speed shown the remote controller display.
 - While the display is in "Standby" or "Defrost" states.
 - When the temperature of the heat exchanger is low in the heating mode. (e.g. immediately after heating operation starts)
 - In HEAT mode, when room temperature is higher than the temperature setting.
 - In COOL mode, when room temperature is lower than the temperature setting.
 - When the unit is in DRY mode.

3.5. Airflow direction setting

3.5.1 Navigating through the Main menu

<Accessing the Main menu>

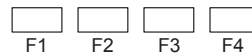
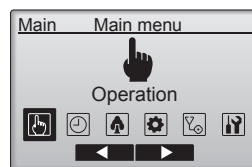

Press the [MENU] button on the Main display.
The Main menu will appear.

<Item selection>

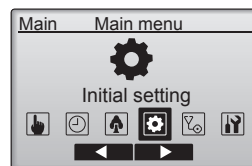

Press [F2] to move the cursor left.
Press [F3] to move the cursor right.

<Exiting the Main menu screen>

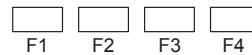
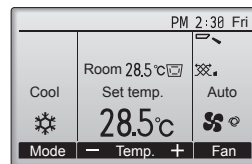

Press the [RETURN] button to exit the Main menu and return to the Main display.

If no buttons are touched for 10 minutes, the screen will automatically return to the Main display. Any settings that have not been saved will be lost.

<Display of unsupported functions>

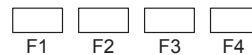
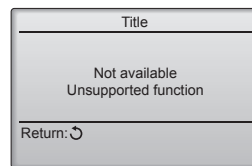

The message at left will appear if the user selects a function not supported by the corresponding indoor unit model.

3. Operation

3.5.2 Vane-Vent. (Lossnay)

<Accessing the menu>

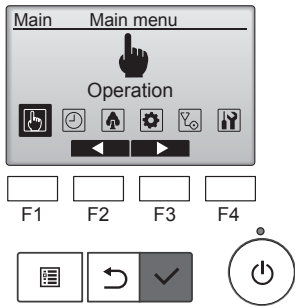

Select "Operation" from the Main menu (refer to 3.5.1), and press the [SELECT] button.

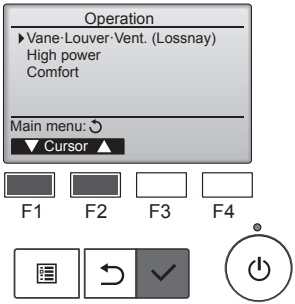

Select "Vane-Louver-Vent. (Lossnay)" from the Operation menu, and press the [SELECT] button.

<Vane setting>

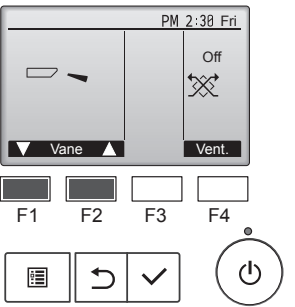

Press the [F1] or [F2] button.

Press the button as indicated above to go through the following setting options.

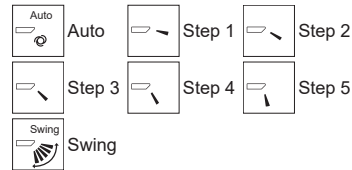

Select "Swing" to move the vanes up and down automatically. When set to "Step 1" through "Step 5", the vane will be fixed at the selected angle.

<Vent. setting>

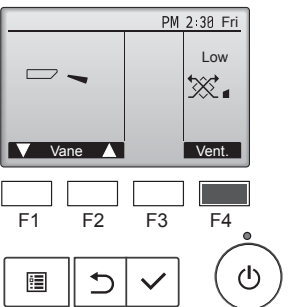

Press the [F4] button to go through the ventilation setting options in the order of "Off", "Low", and "High".

* Settable only when LOSSNAY unit is connected.



• The fan on some models of indoor units may be interlocked with certain models of ventilation units.

<Returning to the Main menu>

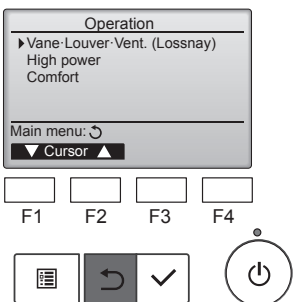

Press the [RETURN] button to go back to the Main menu.

Note:

- During swing operation, the directional indication on the screen does not change in sync with the directional vanes on the unit.
- Available directions depend on the type of unit connected.
- In the following cases, the actual air direction will differ from the direction indicated on the remote controller display.
 1. While the display is in "Standby" or "Defrost" states.
 2. Immediately after starting heat mode (while the system is waiting for the mode change to take effect).
 3. In heat mode, when room temperature is higher than the temperature setting.

<[Manual] To Change the Airflow's Left/Right Direction>

* The louver button cannot be used.

- Stop the unit operation, hold the lever of the louver, and adjust to the desired direction.

* Do not set to the inside direction when the unit is in the cooling or drying mode because there is a risk of condensation and water dripping.



⚠ **Caution:**

To prevent falls, maintain a stable footing when operating the unit.

3.6. Ventilation

For LOSSNAY combination

■ The following 2 patterns of operation is available.

- Run the ventilator together with indoor unit.
- Run the ventilator independently.

Note: (for wireless remote controller)

- Running the ventilator independently is not available.
- No indication on the remote controller.

4. Timer

4.1. For Wired Remote-controller

- Timer functions are different by each remote controller.
- For details on how to operate the remote controller, refer to the appropriate operation manual included with each remote controller.

5. Emergency Operation for Wireless Remote-controller

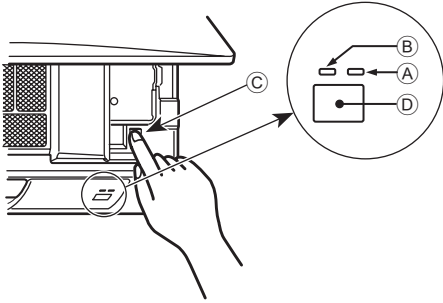

en When the remote controller cannot be used

When the batteries of the remote controller run out or the remote controller malfunctions, the emergency operation can be done using the emergency buttons on the grille.

- Ⓐ DEFROST/STAND BY lamp (Orange)
 - Ⓑ Operation lamp (Green)
 - Ⓒ Emergency operation switch (cooling/heating)
 - Ⓓ Receiver
- Each press of the emergency operation switch will toggle the operation mode.
 - Check "COOL/HEAT" with the operation monitor display. (The display will appear orange for 5 seconds after the switch operation.)

[Combination Cooling and Heating Models]



[Cooling Only Models]



Operation Monitor Display

	GREEN	ORANGE	
STOP	○	○	The display will appear orange for 5 seconds following the switch operation as indicated at the left, and then it will return to the regular display.
COOL	●	○	
HEAT	●	●	

○ Turning off ● Lighting

* Operation details at the time of emergency operation are as shown below.

Operation Mode	COOL	HEAT
Set Temperature	24°C	24°C
Fan Speed	High	High
Airflow Direction Up and Down	Setting 1	Setting 4(5)

6. Care and Cleaning

Filter information

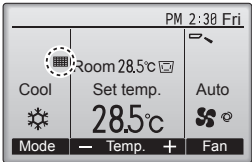

The filter sign icon will appear on the Main display in the Full mode when it is time to clean the filters.

Wash, clean, or replace the filters when this sign appears. Refer to the indoor unit Instructions Manual for details.

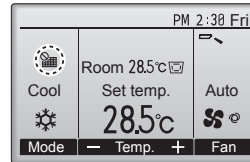

When the filter sign icon with a crossed-out circle is displayed on the Main display in the Full mode, the system is centrally controlled and the filter sign cannot be reset.

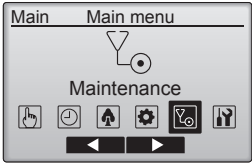

Select "Maintenance" from the Main menu, and press the [SELECT] button.

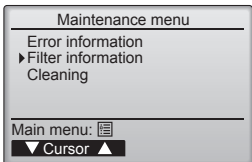
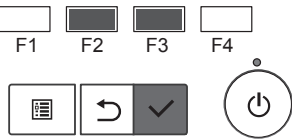

Select "Filter information" from the Maintenance menu, and press the [SELECT] button.

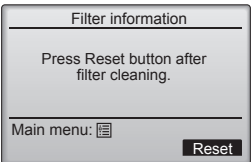
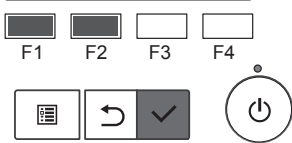

Press the [F4] button to reset filter sign. Refer to the indoor unit Instructions Manual for how to clean the filter.

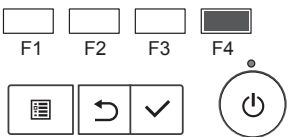

Select "OK" with the [F4] button.

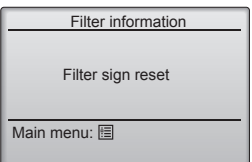
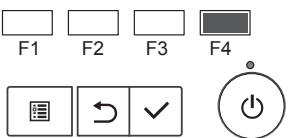

A confirmation screen will appear.

Navigating through the screens

- To go back to the Main menu [MENU] button
- To return to the previous screen [RETURN] button

If two or more indoor units are connected, filter cleaning timing for each unit may be different, depending on the filter type. The icon will appear when the filter on the main unit is due for cleaning. When the filter sign is reset, the cumulative operation time of all units will be reset. The icon is scheduled to appear after a certain duration of operation, based on the premise that the indoor units are installed in a space with ordinary air quality. Depending on the air quality, the filter may require more frequent cleaning. The cumulative time at which filter needs cleaning depends on the model.

- This indication is not available for wireless remote controller.

⚠ Caution:

- Ask authorized people to clean the filter.

Cleaning the filters

- Clean the filters using a vacuum cleaner. If you do not have a vacuum cleaner, tap the filters against a solid object to knock off dirt and dust.
- If the filters are especially dirty, wash them in lukewarm water. Take care to rinse off any detergent thoroughly and allow the filters to dry completely before putting them back into the unit.

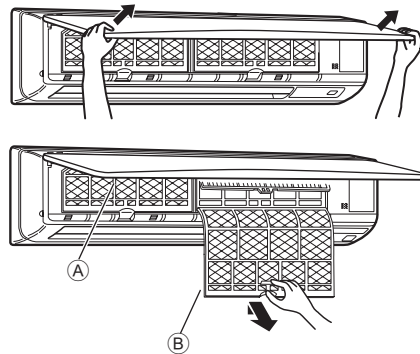

- Using both hands, pull both the bottom corners of the inlet grille to open the grille, then lift the filter until it clicks at the stop position.
 - Hold the knobs on the filter and pull the filter up, then pull it out downward. (Located in two places, on the left and right.)
- Ⓐ Front grille
Ⓑ Filter

⚠ Caution:

- Do not dry the filters in direct sunlight or by using a heat source, such as an electric heater: this may warp them.
- Do not wash the filters in hot water (above 50°C), as this may warp them.
- Make sure that the air filters are always installed. Operating the unit without air filters can cause malfunction.

⚠ Caution:

- Before you start cleaning, stop operation and turn OFF the power supply.
- Indoor units are equipped with filters to remove the dust of sucked-in air. Clean the filters using the methods shown in the sketches above.

6. Care and Cleaning

■ Cleaning the indoor unit

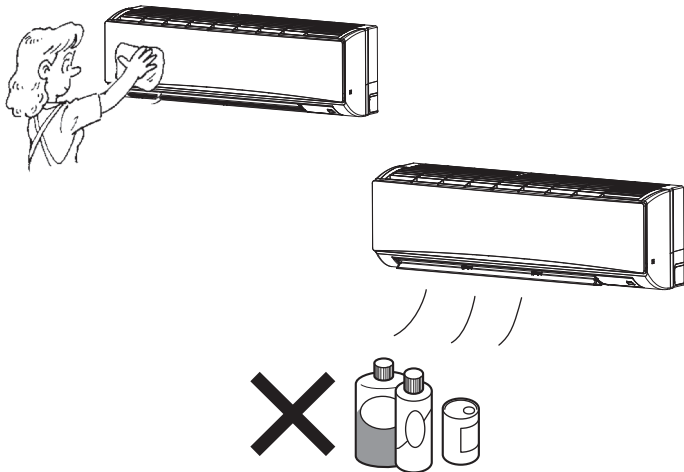







- Wipe the outside of the unit with a clean, dry, soft cloth.
- When dirt stands out, wash it with kitchen neutral detergent diluted with lukewarm water to the specified concentration, then wipe off the detergent with a damp towel.

⚠ Caution:

Never use gasoline, benzene, thinner, scouring powder or any type of non-neutral detergent, as these substances may damage the unit's case.

7. Troubleshooting

Having trouble?	Here is the solution. (Unit is operating normally.)
Air conditioner does not heat or cool well.	<ul style="list-style-type: none"> ■ Clean the filter. (Airflow is reduced when the filter is dirty or clogged.) ■ Check the temperature adjustment and adjust the set temperature. ■ Make sure that there is plenty of space around the outdoor unit. Is the indoor unit air inlet or outlet blocked? ■ Has a door or window been left open?
When heating operation starts, warm air does not blow from the indoor unit soon.	<ul style="list-style-type: none"> ■ Warm air does not blow until the indoor unit has sufficiently warmed up.
During heat mode, the air conditioner stops before the set room temperature is reached.	<ul style="list-style-type: none"> ■ When the outdoor temperature is low and the humidity is high, frost may form on the outdoor unit. If this occurs, the outdoor unit performs a defrosting operation. Normal operation should begin after approximately 10 minutes.
Airflow up/down direction changes during operation or airflow up/down direction cannot be set.	<ul style="list-style-type: none"> ■ During cool mode, the vanes automatically move to the horizontal (down) position after 1 hour when the down (horizontal) airflow up/down direction is selected. This is to prevent water from forming and dripping from the vanes. ■ During heat mode, the vanes automatically move to the horizontal airflow up/down direction when the airflow temperature is low or during defrosting mode.
When the airflow up/down direction is changed, the vanes always move up and down past the set position before finally stopping at the position.	<ul style="list-style-type: none"> ■ When the airflow up/down direction is changed, the vanes move to the set position after detecting the base position.
A flowing water sound or occasional hissing sound is heard.	<ul style="list-style-type: none"> ■ These sounds can be heard when refrigerant is flowing in the air conditioner or when the refrigerant flow is changing.
A cracking or creaking sound is heard.	<ul style="list-style-type: none"> ■ These sounds can be heard when parts rub against each due to expansion and contraction from temperature changes.
The room has an unpleasant odor.	<ul style="list-style-type: none"> ■ The indoor unit draws in air that contains gases produced from the walls, carpeting, and furniture as well as odors trapped in clothing, and then blows this air back into the room.
A white mist or vapor is emitted from the indoor unit.	<ul style="list-style-type: none"> ■ If the indoor temperature and the humidity are high, this condition may occur when operation starts. ■ During defrosting mode, cool airflow may blow down and appear like a mist.
Water or vapor is emitted from the outdoor unit.	<ul style="list-style-type: none"> ■ During cool mode, water may form and drip from the cool pipes and joints. ■ During heat mode, water may form and drip from the heat exchanger. ■ During defrosting mode, water on the heat exchanger evaporates and water vapor may be emitted.
“  ” The operation indicator does not appear in the remote controller display.	<ul style="list-style-type: none"> ■ Turn on the power switch. “” will appear in the remote controller display.
When restarting the air conditioner soon after stopping it, it does not operate even though the ON/OFF button is pressed.	<ul style="list-style-type: none"> ■ Wait approximately 3 minutes. (Operation has stopped to protect the air conditioner.)
Air conditioner operates without the ON/OFF button being pressed.	<ul style="list-style-type: none"> ■ Is the on timer set? Press the ON/OFF button to stop operation. ■ Is the air conditioner connected to a central remote controller? Consult the concerned people who control the air conditioner. ■ Does “” appear in the remote controller display? Consult the concerned people who control the air conditioner. ■ Has the auto recovery feature from power failures been set? Press the ON/OFF button to stop operation.
Air conditioner stops without the ON/OFF button being pressed.	<ul style="list-style-type: none"> ■ Is the off timer set? Press the ON/OFF button to restart operation. ■ Is the air conditioner connected to a central remote controller? Consult the concerned people who control the air conditioner. ■ Does “” appear in the remote controller display? Consult the concerned people who control the air conditioner.
Remote controller timer operation cannot be set.	<ul style="list-style-type: none"> ■ Are timer settings invalid? If the timer can be set,  or  appears in the remote controller display.
“Please Wait” appears in the remote controller display.	<ul style="list-style-type: none"> ■ The initial settings are being performed. Wait approximately 3 minutes.
An error code appears in the remote controller display.	<ul style="list-style-type: none"> ■ The protection devices have operated to protect the air conditioner. ■ Do not attempt to repair this equipment by yourself. Turn off the power switch immediately and consult your dealer. Be sure to provide the dealer with the model name and information that appeared in the remote controller display.
Draining water or motor rotation sound is heard.	<ul style="list-style-type: none"> ■ When cooling operation stops, the drain pump operates and then stops. Wait approximately 3 minutes.

7. Troubleshooting

Having trouble?	Here is the solution. (Unit is operating normally.)												
Noise is louder than specifications.	<ul style="list-style-type: none"> The indoor operation sound level is affected by the acoustics of the particular room as shown in the following table and will be higher than the noise specification, which was measured in an echo-free room. <table border="1"> <thead> <tr> <th></th> <th>High sound-absorbing rooms</th> <th>Normal rooms</th> <th>Low sound-absorbing rooms</th> </tr> </thead> <tbody> <tr> <td>Location examples</td> <td>Broadcasting studio, music room, etc.</td> <td>Reception room, hotel lobby, etc.</td> <td>Office, hotel room</td> </tr> <tr> <td>Noise levels</td> <td>3 to 7 dB</td> <td>6 to 10 dB</td> <td>9 to 13 dB</td> </tr> </tbody> </table>		High sound-absorbing rooms	Normal rooms	Low sound-absorbing rooms	Location examples	Broadcasting studio, music room, etc.	Reception room, hotel lobby, etc.	Office, hotel room	Noise levels	3 to 7 dB	6 to 10 dB	9 to 13 dB
	High sound-absorbing rooms	Normal rooms	Low sound-absorbing rooms										
Location examples	Broadcasting studio, music room, etc.	Reception room, hotel lobby, etc.	Office, hotel room										
Noise levels	3 to 7 dB	6 to 10 dB	9 to 13 dB										
Nothing appears in the wireless remote controller display, the display is faint, or signals are not received by the indoor unit unless the remote controller is close.	<ul style="list-style-type: none"> The batteries are low. Replace the batteries and press the Reset button. If nothing appears even after the batteries are replaced, make sure that the batteries are installed in the correct directions (+, -). 												
After battery installation/replacement of remote controller, part of function cannot be used.	<ul style="list-style-type: none"> Please check that the clock setting is completed. If clock setting is not done, please complete. 												
The operation lamp near the receiver for the wireless remote controller on the indoor unit is flashing.	<ul style="list-style-type: none"> The self diagnosis function has operated to protect the air conditioner. Do not attempt to repair this equipment by yourself. Turn off the power switch immediately and consult your dealer. Be sure to provide the dealer with the model name. 												
The indoor unit which is not operating becomes warm and a sound, similar to water flowing, is heard from the unit.	<ul style="list-style-type: none"> A small amount of refrigerant continues to flow into the indoor unit even though it is not operating. 												

8. Specifications

■ PKA-M-KA(L) Series

Model		60	71	100
Power source (Voltage/Frequency)	<V/Hz>		~N 230/50, 230/60	
Rated Input (Indoor only)	<kW>	0.06	0.06	0.08
Rated Current (Indoor only)	<A>	0.43	0.43	0.57
Heater	<kW>	–	–	–
Dimension (Height)	<mm>	365		
Dimension (Width)	<mm>	1170		
Dimension (Depth)	<mm>	295		
Fan airflow volume (Low-Middle-High)	<m ³ /min>	18-20-22		20-23-26
Noise level (Low-Middle-High)	<dB>	39-42-45		41-45-49
Net weight	<kg>	21		

Model		60	71	100	
Cooling Capacity	sensible	$P_{rated,c}$ <kW>	5.16	5.53	7.30
	latent	$P_{rated,c}$ <kW>	0.84	1.57	2.70
Heating Capacity		$P_{rated,h}$ <kW>	6.90	8.10	11.20
Total electric power input		P_{elec} <kW>	0.060	0.060	0.080
Sound power level (per speed setting, if applicable)		L_{WA} <dB>	58-61-64	58-61-64	58-61-65

(EU)2016/2281

EU DECLARATION OF CONFORMITY
EU-KONFORMITÄTSEKTLÄRUNG
DECLARATION DE CONFORMITÉ UE
EU-CONFORMITEITSVERKLARING
DECLARACIÓN DE CONFORMIDAD UE
DICHIARAZIONE DI CONFORMITÀ UE
ΔΗΛΩΣΗ ΣΥΜΜΟΡΦΩΣΗΣ ΕΕ
DECLARAÇÃO DE CONFORMIDADE UE
EU-OVERENSSTEMMELSESERKLÆRING

EU-FÖRSÄKRAN OM ÖVERENSSTÄMMELSE
AB UYGUNLUK BEYANI
ДЕКЛАРАЦИЯ СООТВЕТСТВИЯ НОРМАМ ЕС
ЕС ДЕКЛАРАЦИЯ ЗА СЪОТВЕТСТВИЕ
ДЕКЛАРАЦЈА ЗГОДНОСТИ UE
EU-ERKLÆRING OM SAMSVAR
EU-VAATIMUSTENMUKAISUUSVAKUUTUS
EU PROHLÁŠENÍ O SHODĚ

EÚ VYHLÁŠENIE O ZHODE
EU MEGFELELŐSÉGI NYILATKOZAT
IZJAVA EU O SKLADNOSTI
DECLARAȚIE DE CONFORMITATE UE
EL-I VASTAVUSDEKLARATSIOON
ES ATBILSTĪBAS DEKLARĀCIJA
ES ATITIKTIES DEKLARACIJA
EU IZJAVA O SUKLADNOSTI
EU IZJAVA O USAGLAŠENOSTI

**MITSUBISHI ELECTRIC CONSUMER PRODUCTS (THAILAND) CO., LTD.
AMATA NAKORN INDUSTRIAL ESTATE 700/406 MOO 7, TAMBON DON HUA ROH, AMPHUR MUANG, CHONBURI 20000, THAILAND**

hereby declares under its sole responsibility that the air conditioner(s) and heat pump(s) for use in residential, commercial, and light-industrial environments described below:
erklärt hiermit auf seine alleinige Verantwortung, dass die Klimaanlage(n) und Wärmepumpe(n) für das häusliche, kommerzielle und leichtindustrielle Umfeld wie unten beschrieben:
déclare par la présente et sous sa propre responsabilité que le(s) climatiseur(s) et la/les pompe(s) à chaleur destinés à un usage dans des environnements résidentiels, commerciaux et d'industrie légère décrits ci-dessous :
verklaart hierbij onder eigen verantwoordelijkheid dat de voor huishoudelijke, handels- en lichtindustriële omgevingen bestemde airconditioner(s) en warmtepomp(en) zoals onderstaand beschreven:
por la presente declara, bajo su exclusiva responsabilidad, que el(los) acondicionador(es) de aire y la(s) bomba(s) de calor previsto(s) para su uso en entornos residenciales, comerciales y de industria ligera que se describen a continuación:
conferma con la presente, sotto la sua esclusiva responsabilità, che i condizionatori d'aria e le pompe di calore destinati all'utilizzo in ambienti residenziali, commerciali e semi-industriali e descritti di seguito:
με το παρόν δηλώνει με αποκλειστική ευθύνη ότι το ή τα κλιματιστικά και η ή οι αντλίες θερμότητας για χρήση σε οικιακά, εμπορικά και ελαφρά βιομηχανικά περιβάλλοντα που περιγράφονται παρακάτω:
declara pela presente, e sob sua exclusiva responsabilidade, que o(s) aparelho(s) de ar condicionado e a(s) bomba(s) de calor destinados a utilização em ambientes residenciais, comerciais e de indústria ligeira descritos em seguida:
erklærer hermed under eneansvar, at det/de herunder beskrevne airconditionanlæg og varmepumpe(r) til brug i beboelses- og erhvervsmiljøer samt i miljøer med let industri:
intyggar härmed att luftkonditioneringarna och varmepumparna som beskrivs nedan för användning i bostäder, kommersiella miljöer och låtta industriella miljöer:
ev, ticaret ve hafif sanayi ortamlarında kullanıma yönelik aşağıda açıklanan klima ve ısıtma pompalarını ilgili aşağıdaki hususları yalnızca kendi sorumluluğunda olmak üzere beyan eder:
настоящим заявляет под свою исключительную ответственность, что кондиционер (-ы) и тепловой (-ые) насос (-ы) для использования в описанных ниже жилых, коммерческих и небольших складских и промышленных помещениях:
цим заявляю, беручи на себе повну відповідальність за це, що кондиціонер (-и) й тепловий (-и) насос (-и), описані нижче й призначені для використання в житлових приміщеннях, торговельних залах і на підприємствах легкої промисловості:
декларира с настоящата на своя собствена отговорност, че климатикът(те) и термопомпата(ите), посочени по-долу и предназначени за употреба в жилища, търговски и лекопромишлени среди:
niniejszym oświadczam na swoją wyłączną odpowiedzialność, że klimatyzatory i pompy ciepła do zastosowań w środowisku mieszkalnym, handlowym i lekko przemysłowym opisane poniżej:
erklærer et fullstendig ansvar for undernevnte klimaanlegg og varmepumper ved bruk i boliger, samt kommersielle og lettindustrielle miljøer:
vakuuttaa täten yksinomaisella vastuullaan, että jäljempänä kuvutat asuinrakennuksiin, pienteollisuuskäyttöön ja kaupalliseen käyttöön tarkoitettut ilmastointilaitteet ja lämpöpumput:
tímto na vlastní odpovědnost prohlašuje, že níže popsané klimatizační jednotky a tepelná čerpadla pro použití v obytných prostředích, komerčních prostředích a prostředích lehkého průmyslu:
týmto na svoju výlučnú zodpovednosť vyhlasuje, že nasledovné klimatizačné jednotky a tepelné čerpadlá určené na používanie v obytných a obchodných priestoroch a v prostredí ľahkého priemyslu:
alulírott kizárólagos felelősségére nyilatkozok, hogy az alábbi lakossági, kereskedelmi és kisipari környezetben való használatra szánt klímaberendezés(ek) és hőszivattyú(k):
na lastno odgovornost izjavlja, da so spodaj opisane klimatske naprave in toplotne črpalke, namenjene za uporabo v stanovanjskih, poslovnih in lahkoindustrijskih okoljih:
declară prin prezenta, pe proprie răspundere, faptul că aparatele de climatizare și pompele de căldură descrise mai jos și destinate utilizării în medii rezidențiale, comerciale și din industria ușoară:
kinnitab oma ainuvastutusel, et allpool toodud elu-, äri- ja kergtööstuskeskkondades kasutamiseks mõeldud kliimaseadmed ja soojuspumbad:
ar šo, vienpersoniski uzņemoties atbildību, paziņo, ka tālāk aprakstītais(-tie) gaisa kondicionētājs(-i) un siltumsūkņis(-i) ir paredzēti lietošanai dzīvojamajās, komercdarbības un vieglās rūpniecības telpās, kas aprakstītas tālāk:
šiuo vien tik savo atsakomybe pareiškia, kad toliau apibūdintas (-i) oro kondicionierius (-iai) ir šilumos siurblys (-iai), skirtas (-i) naudoti toliau apibūdintose gyvenamosiose, komercinėse ir lengvosios pramonės aplinkose:
ovime izjavljuje pod isključivom odgovornošću da je/su klimatizacijski uređaji(i) i toplinska dizalica(e) opisan(i) u nastavku namijenjen(i) za upotrebu u stambenim i poslovnim okruženjima te okruženjima lake industrije:
ovim izjavljuje na svoju isključivu odgovornost da su klima-uređaji i toplotne pumpe za upotrebu u stambenim, komercijalnim okruženjima i okruženjima lake industrije opisani u nastavku:

**MITSUBISHI ELECTRIC, PKA-M60KA*, PKA-M71KA*, PKA-M100KA*
PKA-M60KAL*, PKA-M71KAL*, PKA-M100KAL*
* : , , 1, 2, 3, . . . , 9**

is/are in conformity with provisions of the following Union harmonisation legislation.
die Bestimmungen der folgenden Harmonisierungsrechtsvorschriften der Union erfüllt/erfüllen.
est/sont conforme(s) aux dispositions de la législation d'harmonisation de l'Union suivante.
voldoet/voldoen aan bepalingen van de volgende harmonisatiewetgeving van de Unie.
cumple(n) con las disposiciones de la siguiente legislación de armonización de la Unión.
sono in conformità con le disposizioni della seguente normativa dell'Unione sull'armonizzazione.
συμμορφώνονται με τις διατάξεις της ακόλουθης νομοθεσίας εναρμόνισης της Ένωσης.
está/estão em conformidade com as disposições da seguinte legislação de harmonização da União.
er i overensstemmelse med bestemmelserne i følgende harmoniserede EU-lovgivning.
uppfyller villkoren i följande harmoniserade föreskrifter inom unionen.
aşağıdaki Avrupa Birliği uyumlaştırma mevzuatının hükümlerine uygundur.
соответствуют положениям следующих законодательных актов Союза о гармонизации.

відповідають положенням вказаного далі законодавства Союзу щодо гармонізації.
е/са в съответствие с разпоредбите на следното законодателство на Съюза за хармонизация.
sa zgodne z przepisami następującego unijnego prawodawstwa harmonizacyjnego.
er i samsvar med forskriftene til følgende EU-lovgivning om harmonisering.
ovat unionin seuraavan yhdenmukaistamislainsäädännön säännösten mukaisia.
jsou v souladu s ustanoveními následujících harmonizačních právních předpisů Unie.
splňajú ustanovenia nasledujúcich harmonizovaných noriem EÚ.
megfelelnek az Unió alábbi harmonizációs jogszabályi előírásainak.
v skladu z določbami naslednje usklajevalne zakonodaje Unije.
sunt în conformitate cu dispozițiile următoare legislației de armonizare a Uniunii.
vastavad järgmist Euroopa Liidu ühtlustatud õigusaktide sätetele.
atbilst šādai ES harmonizētajiem tiesību aktu noteikumiem.
taip pat atitinka kitų toliau išvardytų suderintųjų Sąjungos direktyvų nuostatas.
sukladan(i) odredbama sljedećeg zakonodavstva Unije za sukladnost.
u skladu sa odredbama sledećeg usklađivanja zakonodavstva Unije.

**2014/35/EU: Low Voltage Directive
2006/42/EC: Machinery Directive
2014/30/EU: Electromagnetic Compatibility Directive
2011/65/EU, (EU) 2015/863 and (EU) 2017/2102: RoHS Directive
2009/125/EC: Energy-related Products and Regulation (EU) No 206/2012**

Issued:
THAILAND

1 July, 2021

Tadashi SAITO
Manager Quality Assurance Department

UK DECLARATION OF CONFORMITY

mitsubishi electric consumer products (thailand) co., ltd.
amata nakorn industrial estate 700/406 moo 7, tambon don hua roh, amphur muang, chonburi 20000, thailand

hereby declares under its sole responsibility that the air conditioners and heat pumps described below for use in residential, commercial and light-industrial environments:

MITSUBISHI ELECTRIC, PKA-M60KA*, PKA-M71KA*, PKA-M100KA*
PKA-M60KAL*, PKA-M71KAL*, PKA-M100KAL*
*** : , , 1, 2, 3, . . . , 9**

Note: Its serial number is on the nameplate of the product.

Legislation

Electrical Equipment (Safety) Regulations 2016
Supply of Machinery (Safety) Regulations 2008
Electromagnetic Compatibility Regulations 2016
The Restriction of the Use of Certain Hazardous Substances in Electrical and Electronic Equipment Regulations 2012
The Ecodesign for Energy-Related Products and Energy Information

Issued: 1 July, 2021
THAILAND

Tadashi SAITO
Manager Quality Assurance Department

This product is designed and intended for use in the residential, commercial and light-industrial environment.

Importer in European and surrounding region.

Mitsubishi Electric Europe B.V.
Capronilaan 34, 1119 NS, Schiphol Rijk, The Netherlands

French Branch
2, Rue De L'Union, 92565 RUEIL MAISON Cedex



German Branch
Mitsubishi-Electric-Platz 1 40882 Ratingen North Rhine-Westphalia Germany

Belgian Branch
8210 Loppem, Autobaan 2, Belgium

Irish Branch
Westgate Business Park, Ballymount Road, Upper Ballymount, Dublin 24, Ireland

Italian Branch
Via Energy Park, 14 20871 Vimercate (MB), Italy

Norwegian Branch
Gneisveien 2D, 1914 Ytre Enebakk, Norway

Portuguese Branch
Avda. do Forte 10, 2794-019 Carnaxide, Lisbon, Portugal

Spanish Branch
Av. Castilla, 2 Parque Empresarial San Fernando - Ed. Europa, 28830 San Fernando de Henares (Madrid), Spain

Scandinavian Branch
Hammarbacken 14, P.O. Box 750, SE-19127, Sollentuna, Sweden

UK Branch
Travellers Lane, Hatfield, Hertfordshire, AL10 8XB, United Kingdom

Polish Branch
Krakowska 50, PL-32-083 Balice, Poland

MITSUBISHI ELECTRIC TURKEY ELEKTRİK ÜRÜNLERİ A.Ş
Şerifali Mahallesi Kale Sokak No: 41 34775 Ümraniye, İstanbul, Turkey

ООО «Мицубиси Электрик (РУС)»
115114, Российская Федерация, г. Москва, ул. Летниковская, д. 2, стр. 1, 5 этаж

Please be sure to put the contact address/telephone number on this manual before handing it to the customer.



MITSUBISHI ELECTRIC CORPORATION

HEAD OFFICE: TOKYO BUILDING, 2-7-3, MARUNOUCHI, CHIYODA-KU, TOKYO 100-8310, JAPAN